

Hybrid Power System Modeling Overview

Ben Kroposki

National Renewable Energy Laboratory

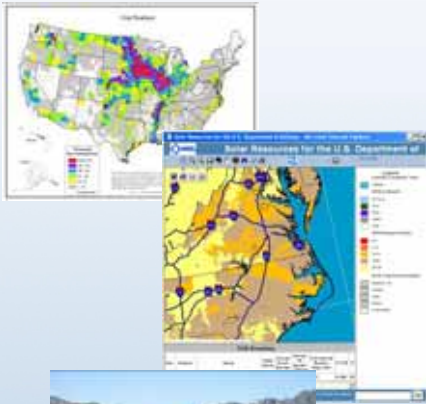

Hybrid Power System Modeling Tools

- **HOMER**
 - Contact: Peter Lilianthal
 - peter@greenislandpower.com
- **VIPOR**
 - Contact: Tom Lambert
 - tomlambert@mistaya.ca
- **Hybrid2**
 - Contact: Ian Barring-Gould
 - ian_baring-gould@nrel.gov

HOMER Overview

Dr. Peter Lilienthal
peter@greenislandpower.com

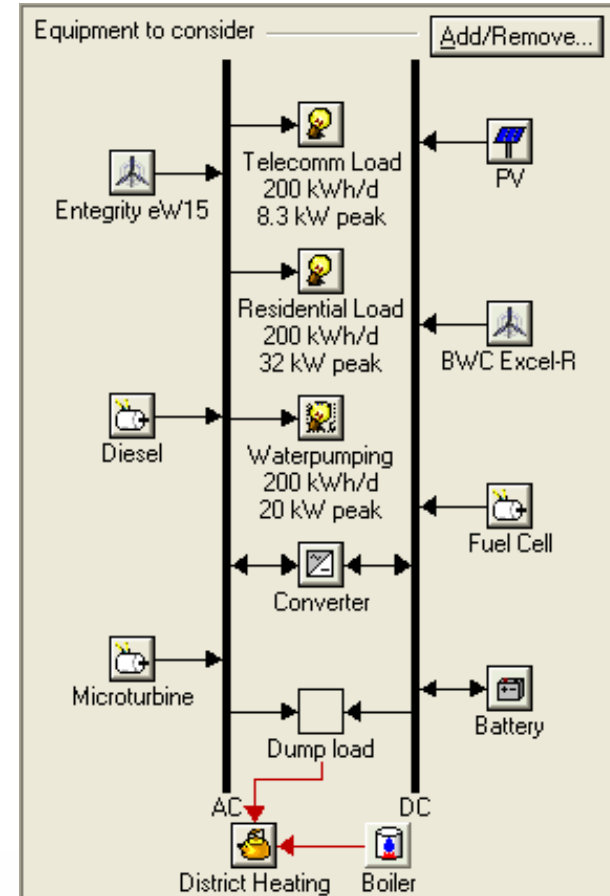

History

- 1993 Village Power
 - Internal NREL use
- 1998 Version 1.0
 - Publicly available Windows application
- 2001 Version 2.0
 - Grid-connected systems, multiple diesels, cogen, hydrogen, emissions
- 2006 Version 2.2
 - Web link for solar resource data, time-of-use rates, flow batteries, real time prices
 - 25,000 users in 191 countries
- 2008 Commercialization license

Fundamental HOMER Question

- Which technologies are most cost-effective?

- Micropower
- Renewables; PV, Wind, Bio, Hydro
- Fossil
- Cogeneration
- Hybrids

- It depends on application

- Resources
- Loads
- Equipment prices
- Equipment performance

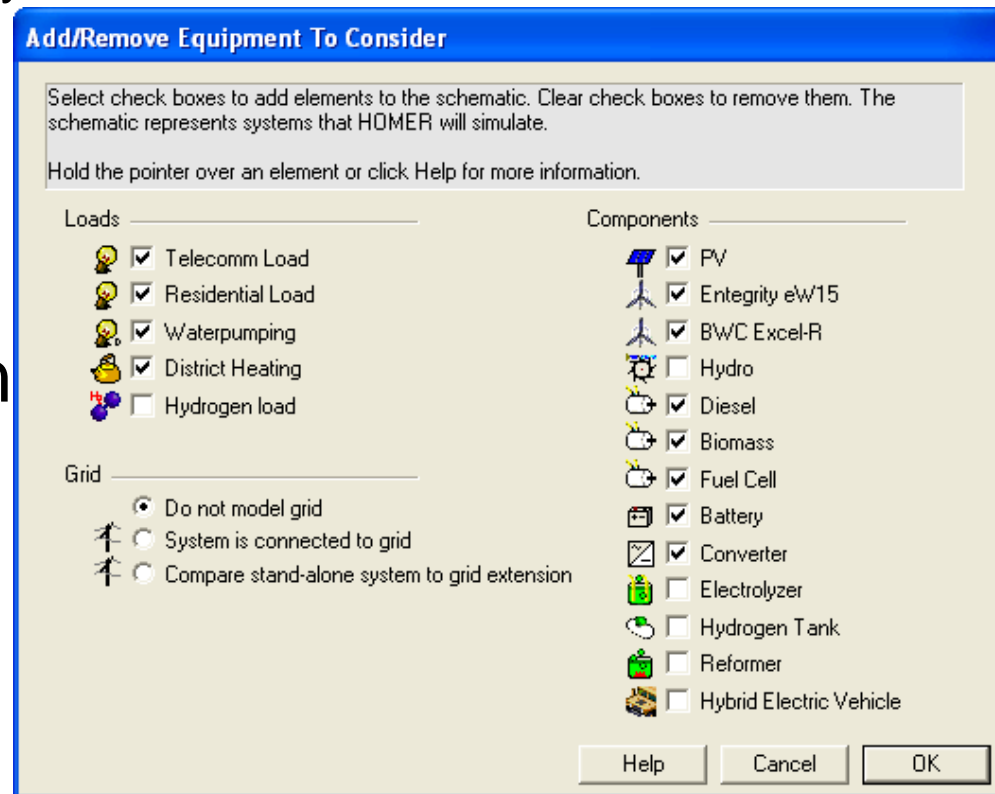

- A confused Mind Says No!

HOMER is Flexible

- Estimated inputs for general analysis
- Detailed inputs for system design
- 8760 hour simulations
- Optimization
- Sensitivity Analysis

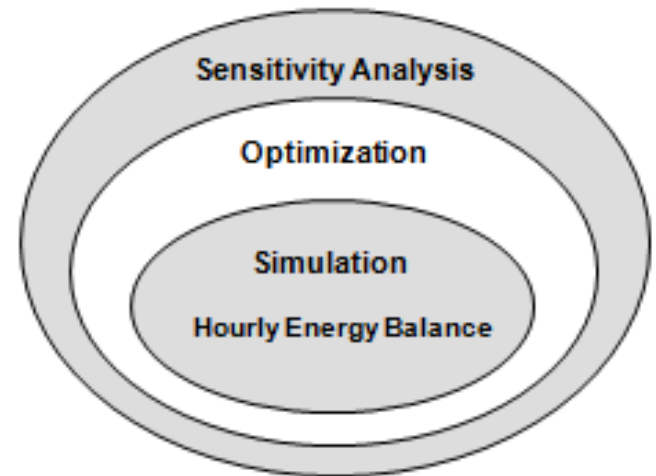

Answers from HOMER

- Optimal System Design
- Cost Breakdowns and Comparisons
- Resource Analysis
- Technology Development Targets
- Policy Analysis
- Operational Analysis

Optimal System Design

- What kind of system is best under which conditions?

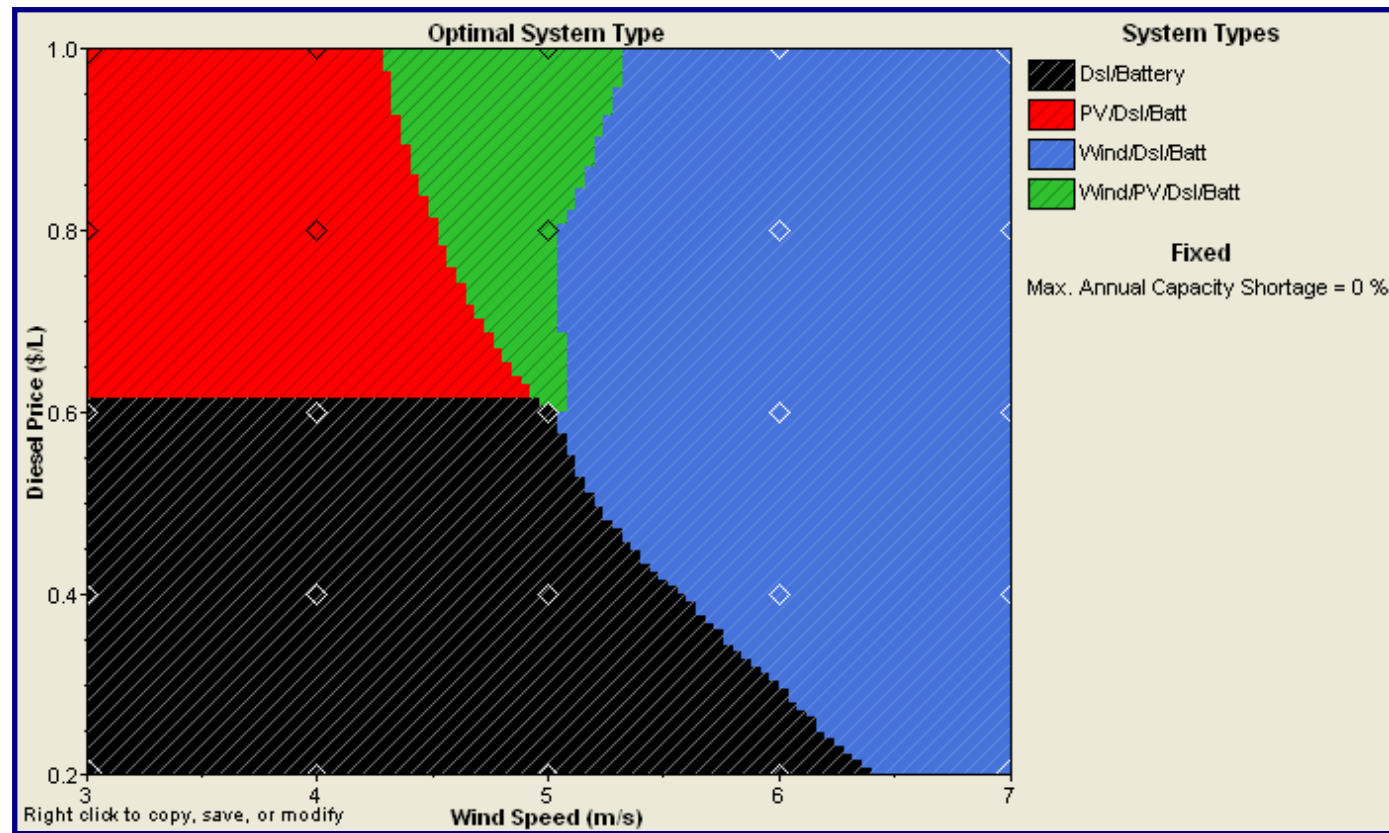

Combining sensitivity and optimization identifies design thresholds.
e.g. minimum fuel price for cost-effective PV

Cost Breakdowns and Comparisons

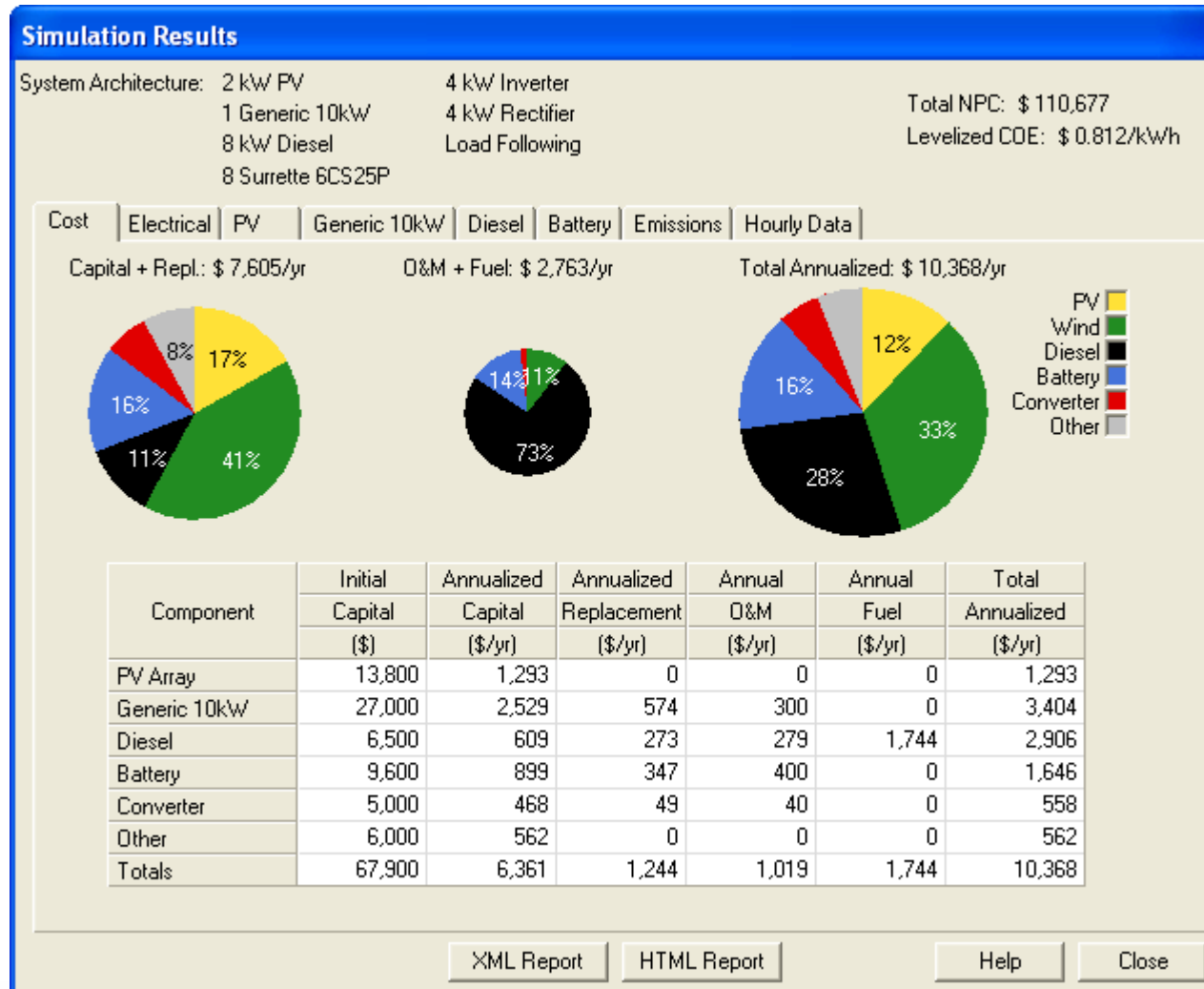

Policy Analysis

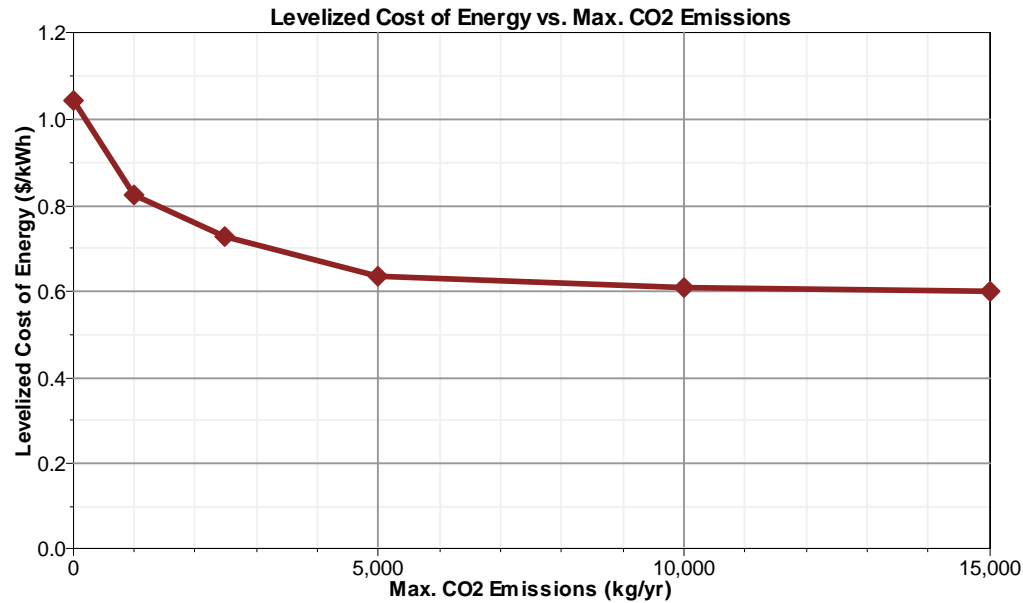

- Cost of emission constraints

Other HOMER Applications

- Net Metering
- Time of day rates
- Emissions

Rates | Emissions | Advanced

Scheduled rates Real time prices

Step 1: Define and select a rate

Rate	Price (\$/kWh)	Sellback (\$/kWh)	Demand (\$/kW/mo)
Rate 1	0.100	0.050	0.000
Rate 2	0.180	0.050	0.000

Add Remove Edit...

Step 2: Select a time period

All Week Weekdays Weekends

Step 3: Click on the chart to indicate when the selected rate applies.

Net metering

Net purchases calculated monthly

Net purchases calculated annually

Rate Schedule

Time of Day

00:00
04:00
08:00
12:00
16:00
20:00
24:00

Jan Feb Mar Apr May Jun Jul Aug Sep Oct Nov Dec

Legend:
Rate 1 (Green)
Rate 2 (Yellow)
All week (Black)
Weekdays (White)
Weekends (Grey)

HOMER's Future

- Still available from: www.nrel.gov/homer
- New website coming before 2009
- Current version will always be free
- Under development
 - New simpler free version
 - Application-specific versions
 - Customized versions
- Contact - Dr. Peter Lilienthal
 - peter@greenislandpower.com
 - 1-720-565-4046

What is ViPOR?

A design tool for rural electrification

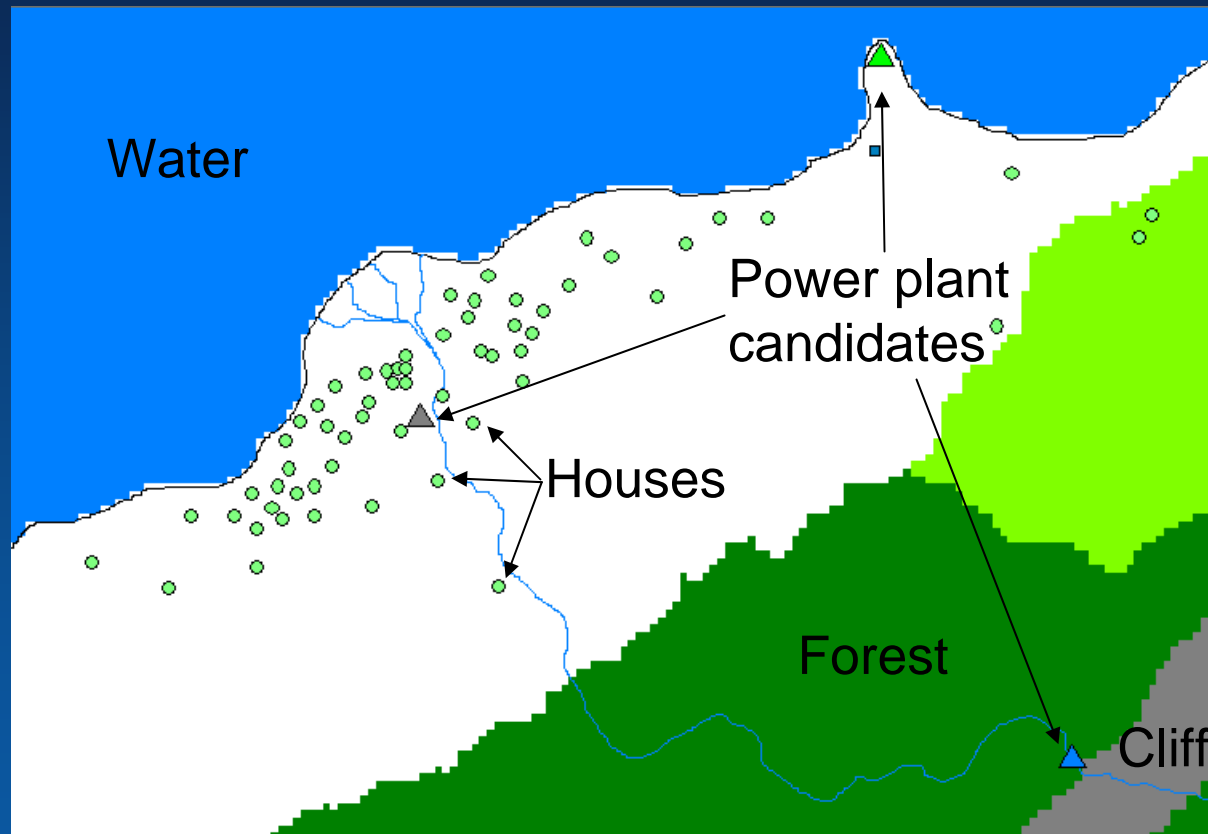

Rural Electrification Complexities

- Wide variation in load density and spatial distribution
- Many possibilities for power generation (household systems, mini-grid, grid extension)
- Terrain affects distribution costs

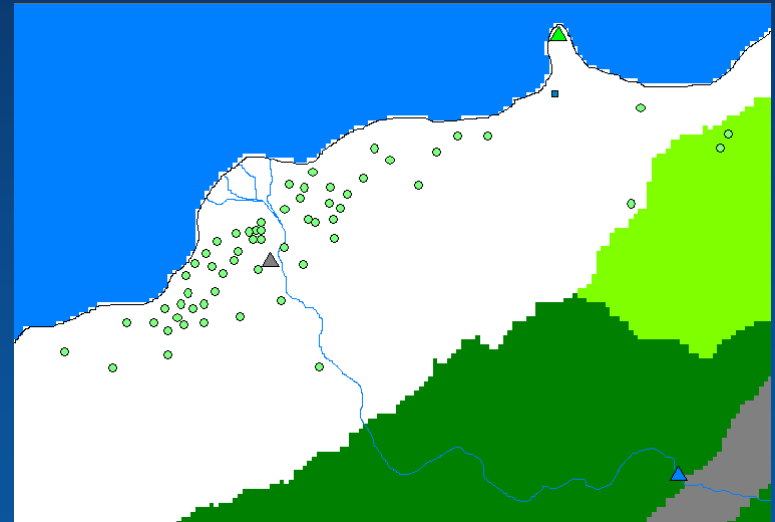

Rural Electrification Complexities

- Different power plant candidates have different costs

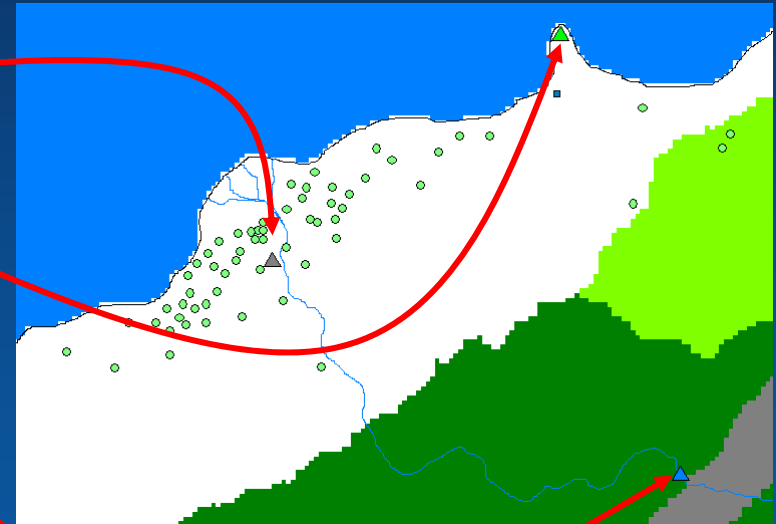
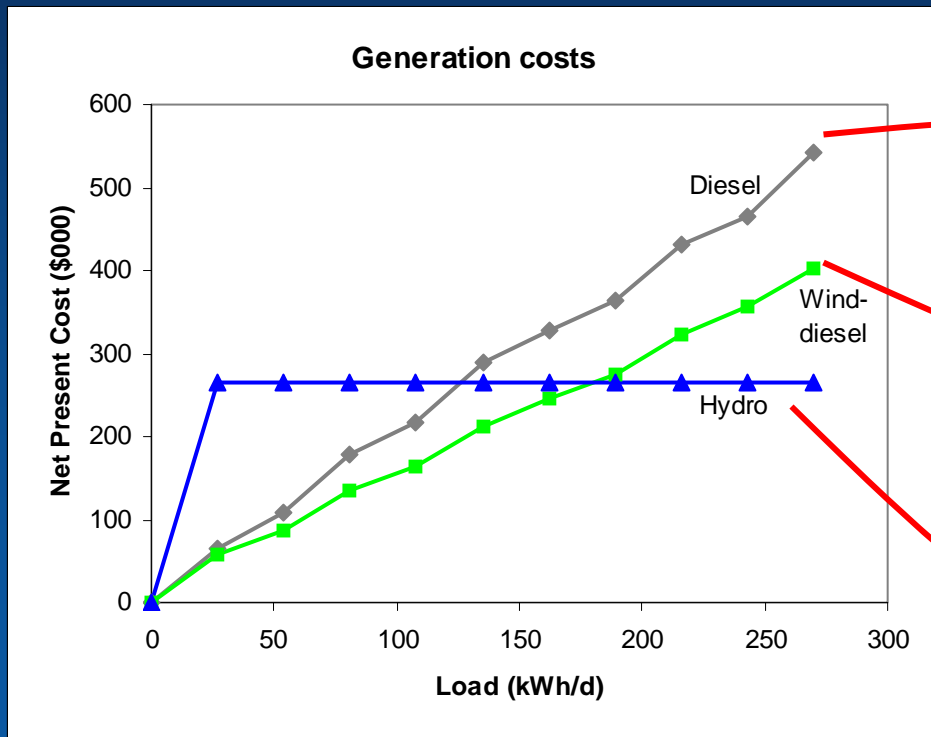

The Role of ViPOR

Helps with difficult design decisions:

- Should power generation be centralized, dispersed or some combination?
- Among several power plant candidates, which is best?
- How should the distribution grid be designed?

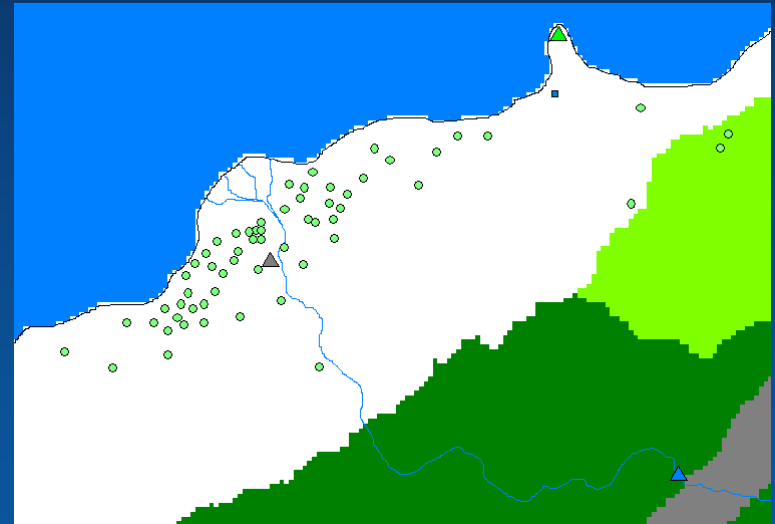

Sample Solution

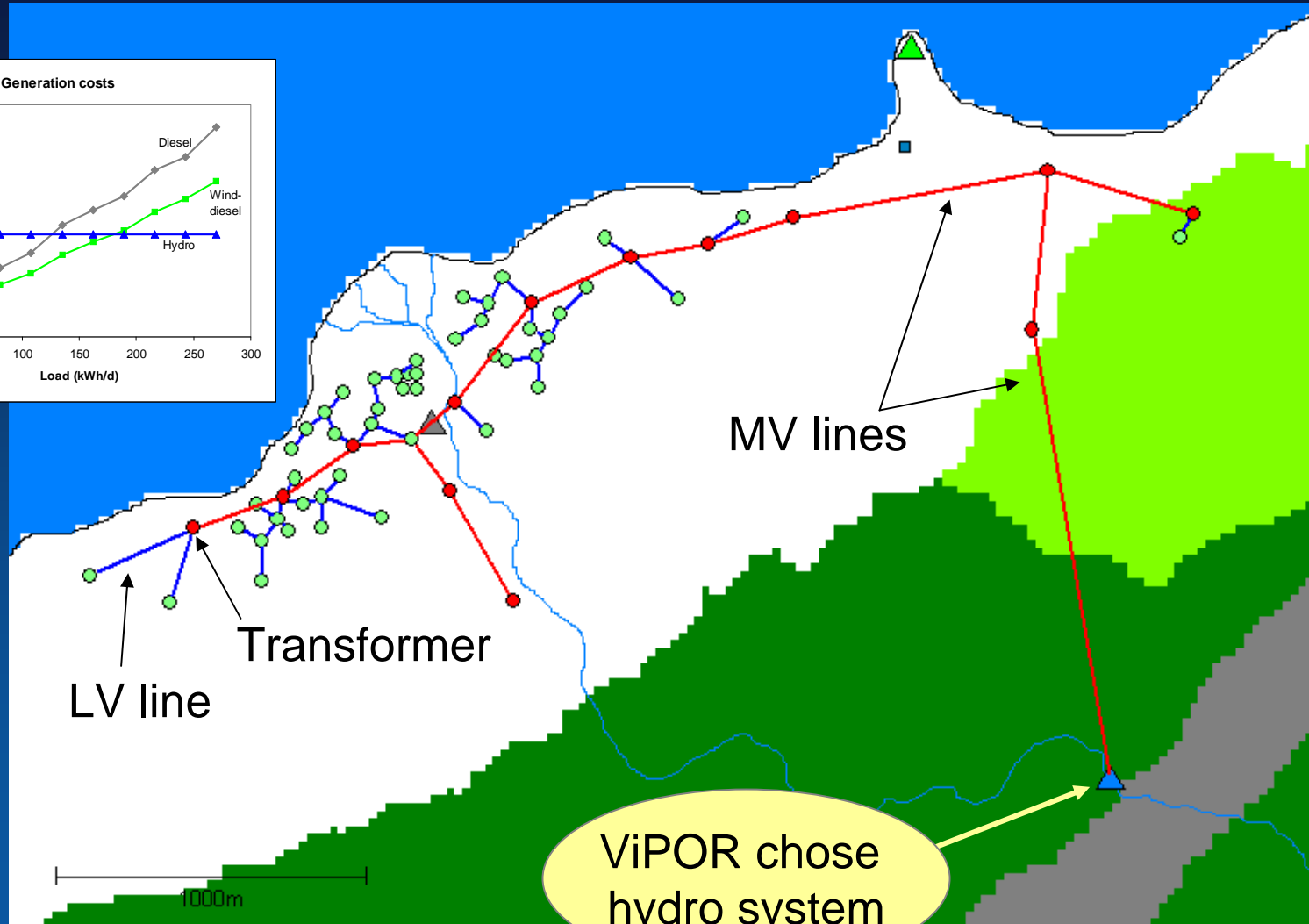

ViPOR chose hydro system

V iPOR works with HOMER

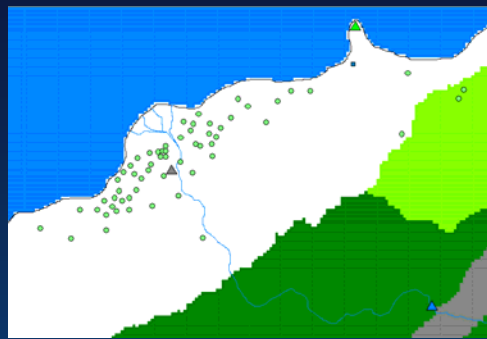

GIS data

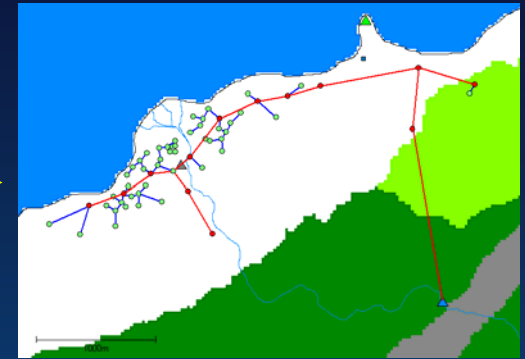

- Minigrid layout
- Estimated cost

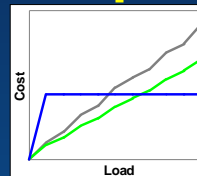

Generation costs

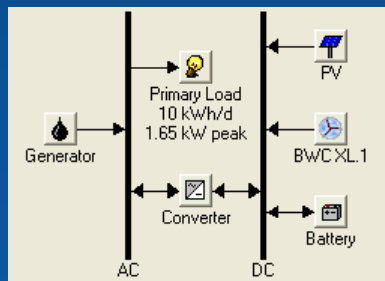

Central power system

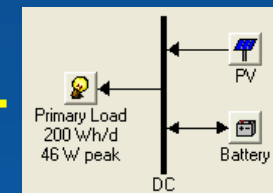
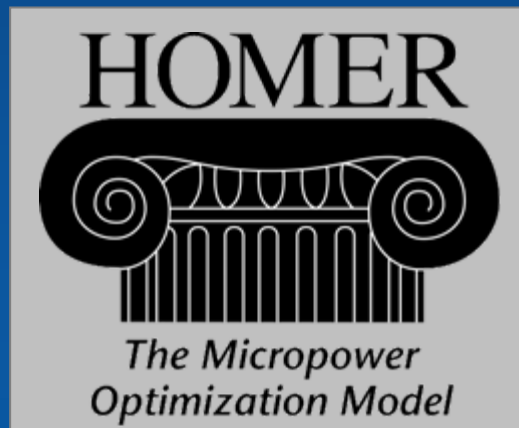

Household power system

Inputs

- Map showing loads, terrain, and power plant sites

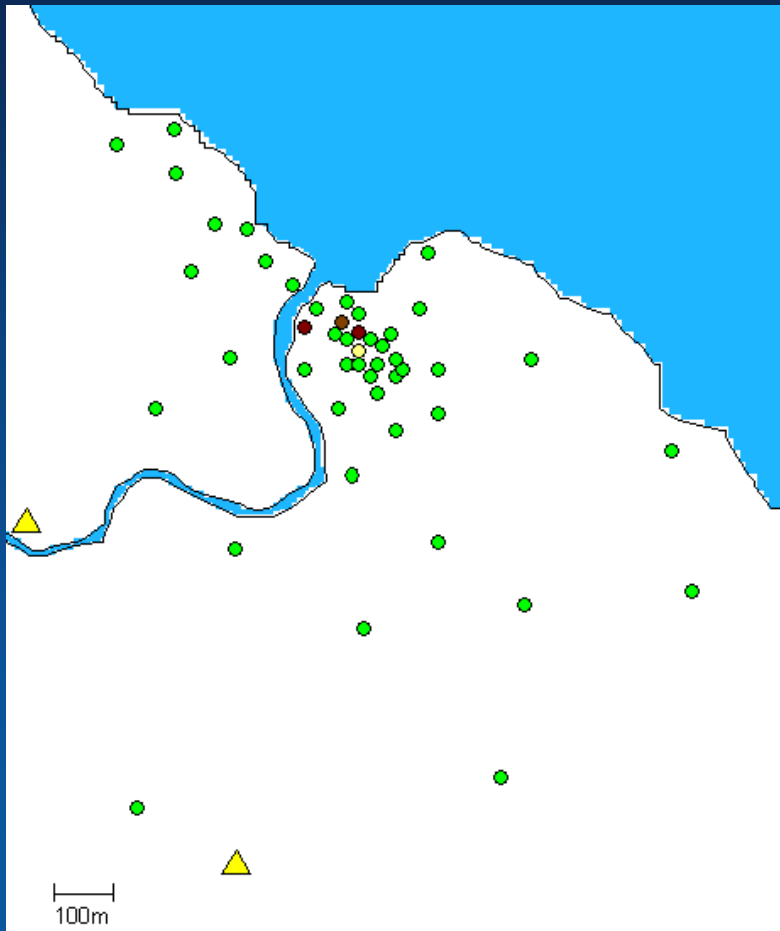

Data can be:

- Digitized from maps
- Imported from GIS or GPS
- Drawn on the screen

Inputs

- Map showing loads, terrain, and power plant sites
- Expected electrical demands

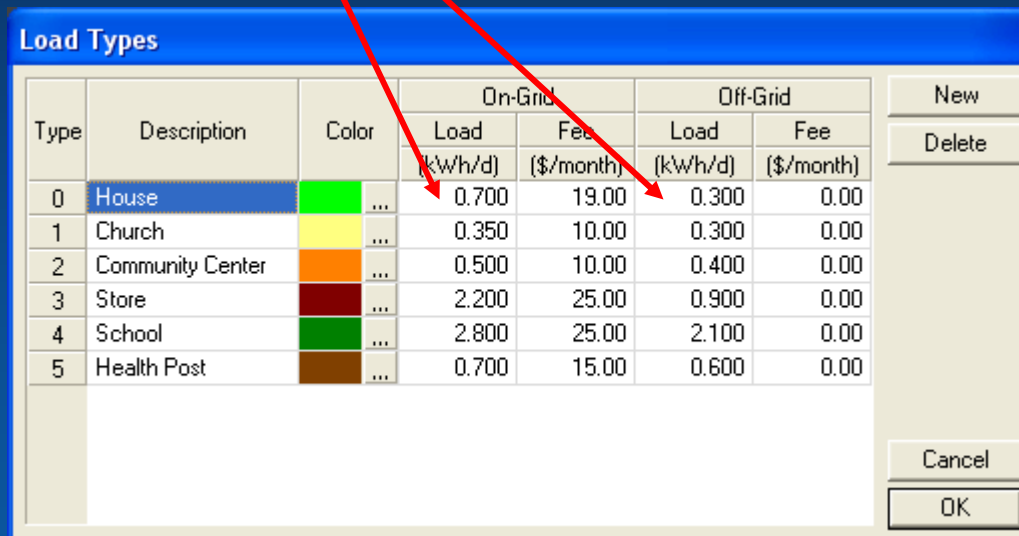

Type	Description	Color	On-Grid		Off-Grid	
			Load (kWh/d)	Fee (\$/month)	Load (kWh/d)	Fee (\$/month)
0	House	...	0.700	19.00	0.300	0.00
1	Church	...	0.350	10.00	0.300	0.00
2	Community Center	...	0.500	10.00	0.400	0.00
3	Store	...	2.200	25.00	0.900	0.00
4	School	...	2.800	25.00	2.100	0.00
5	Health Post	...	0.700	15.00	0.600	0.00

On-grid load
can be different
from off-grid
load

Inputs

- Map showing loads, terrain, and power plant sites
- Expected electrical demands
- Tariffs

Type	Description	Color	On-Grid		Off-Grid	
			Load (kWh/d)	Fee (\$/month)	Load (kWh/d)	Fee (\$/month)
0	House	...	0.700	19.00	0.300	0.00
1	Church	...	0.350	10.00	0.300	0.00
2	Community Center	...	0.500	10.00	0.400	0.00
3	Store	...	2.200	25.00	0.900	0.00
4	School	...	2.800	25.00	2.100	0.00
5	Health Post	...	0.700	15.00	0.600	0.00

Fee for grid power can be different from fee for off-grid system

Inputs

- Map showing loads, terrain, and power plant sites
- Expected electrical demands
- Tariffs
- Electrical generation costs for isolated and centralized power systems



HOMER calculates these costs

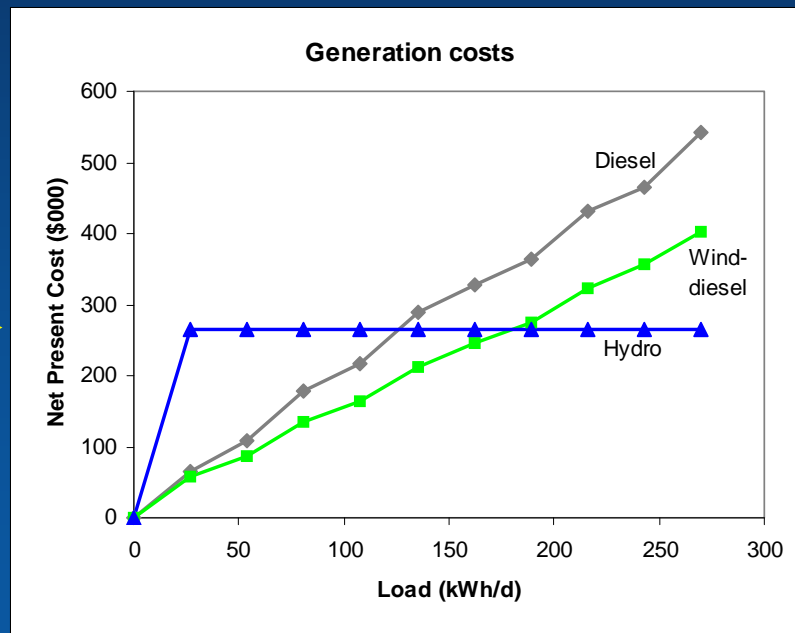

Inputs

- Map showing loads, terrain, and power plant sites
- Expected electrical demands
- Tariffs
- Electrical generation costs for isolated and centralized power systems
- Wire and transformer costs

Wire	Transformers
Low Voltage Line	
Capital Cost:	<input type="text" value="4"/> \$/m
O&M Cost:	<input type="text" value="10"/> % of capital per year
Lifetime:	<input type="text" value="25"/> yr
Medium Voltage Line	
Capital Cost:	<input type="text" value="8"/> \$/m
O&M Cost:	<input type="text" value="0"/> % of capital per year
Lifetime:	<input type="text" value="25"/> yr

Inputs

- Map showing loads, terrain, and power plant sites
- Expected electrical demands
- Tariffs
- Electrical generation costs for isolated and centralized power systems
- Wire and transformer costs
- Maximum low-voltage line length

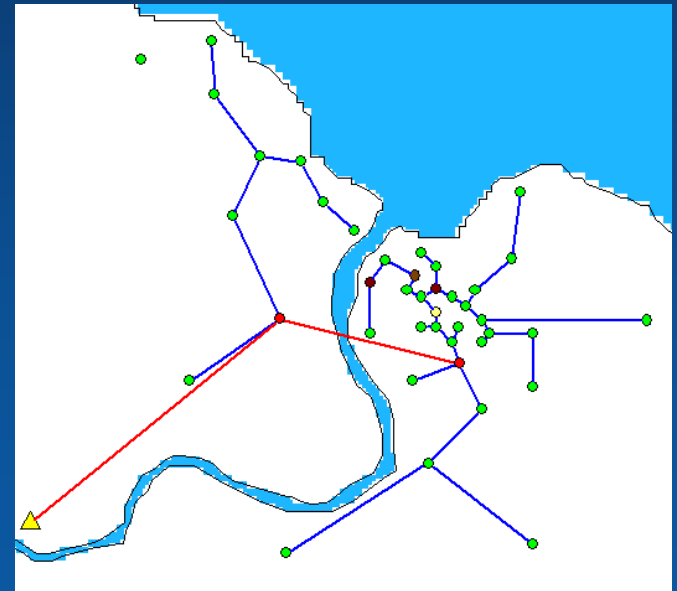

Model Availability

- **V iP O R** is not as fully developed as HOMER
- We encourage **V iP O R** users to work closely with NREL
- Pre-release version available from <http://analysis.nrel.gov/vipor>

More Sample Solutions

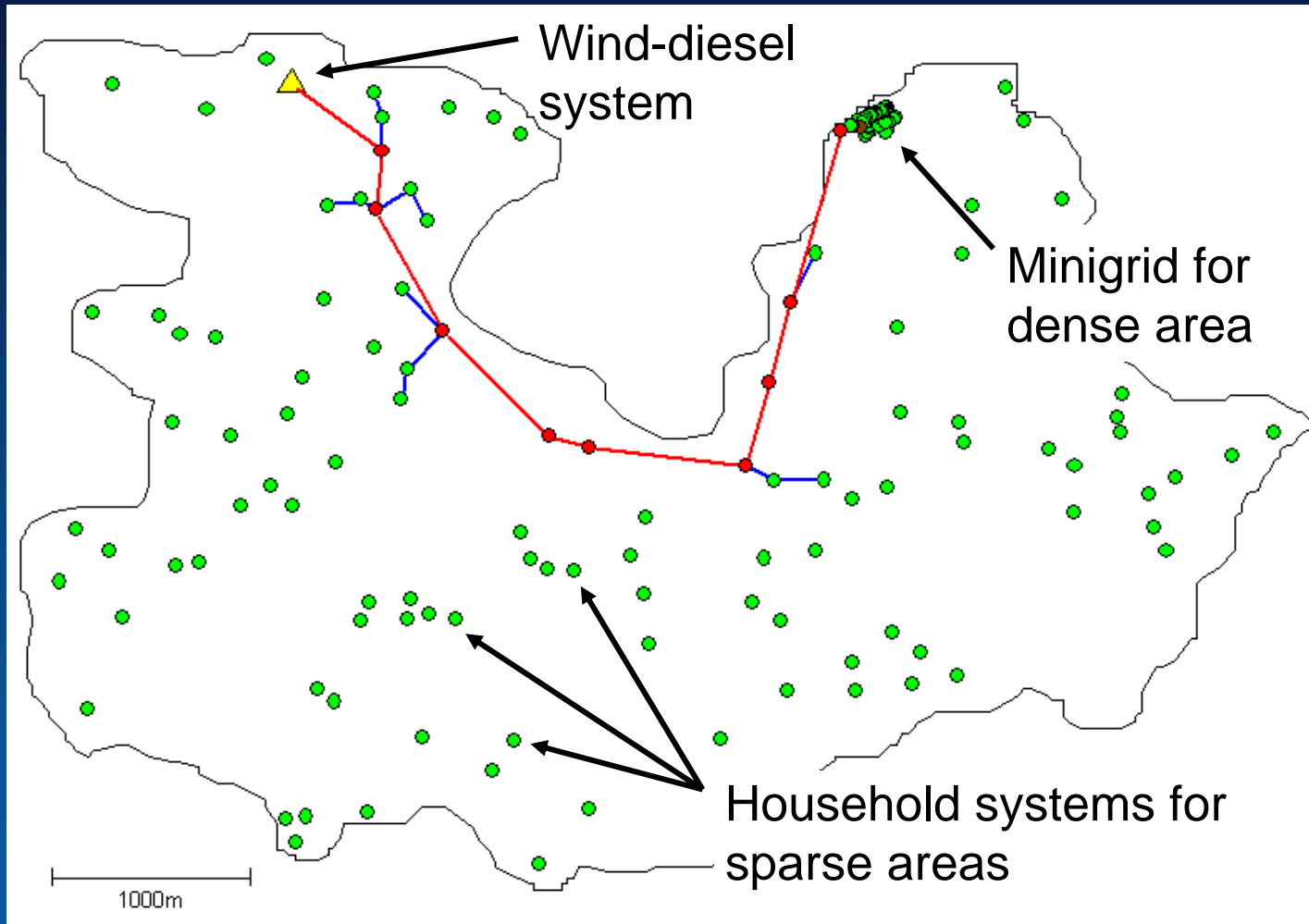

Isla Quenac, Chile

More Sample Solutions

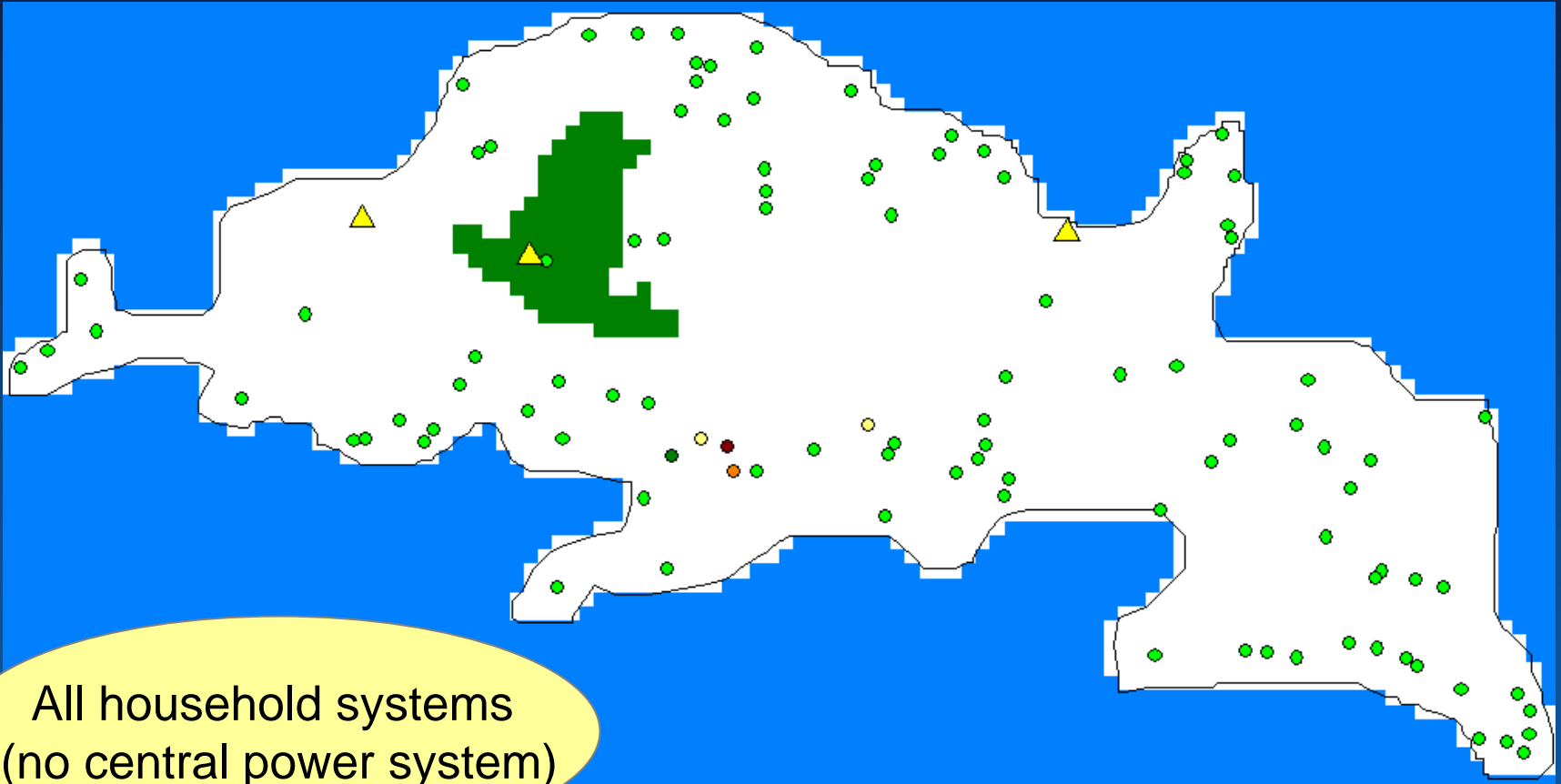

All household systems
(no central power system)

Isla Alao, Chile

More Sample Solutions

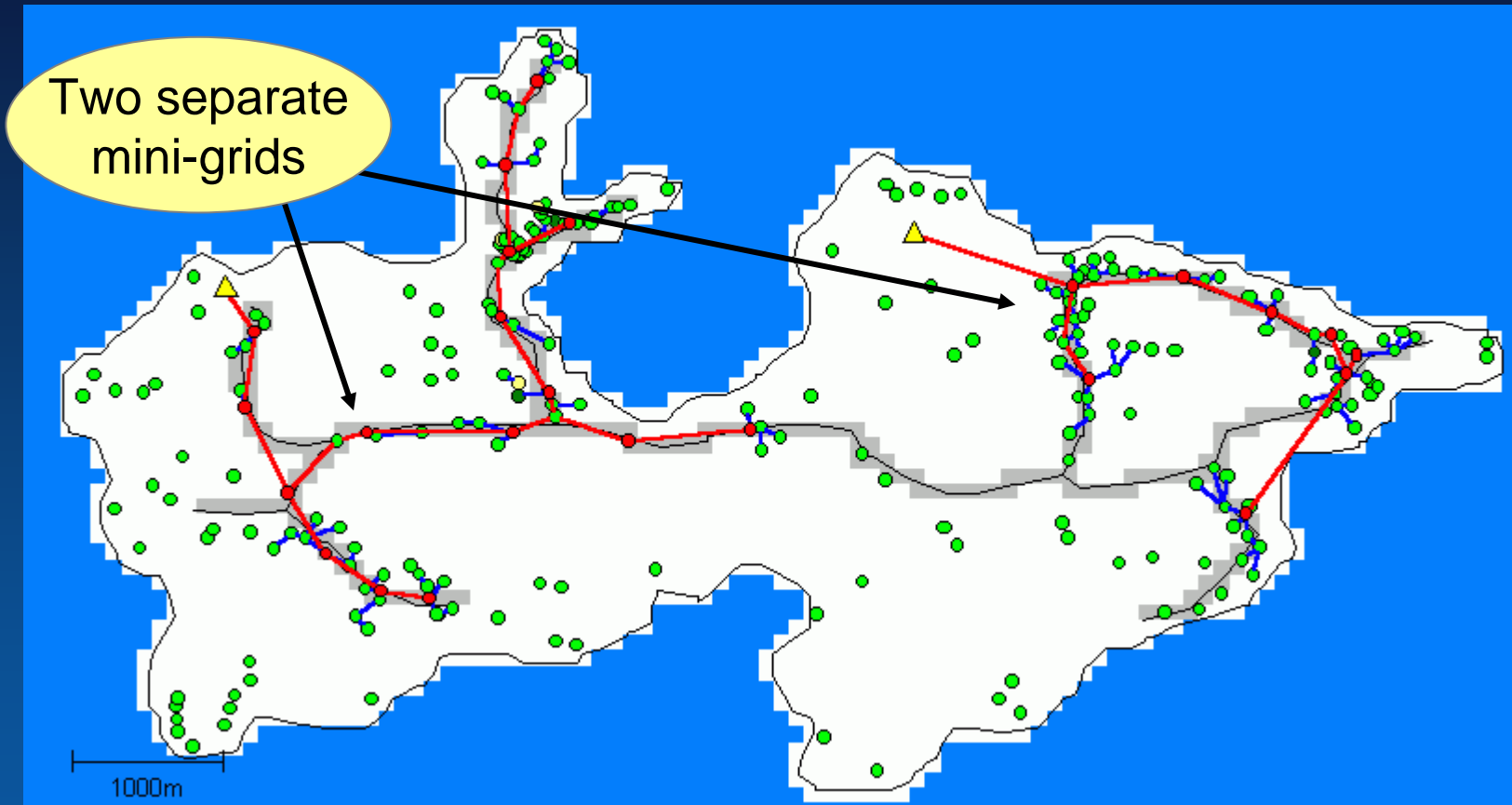

Isla Quehui, Chile

Hybrid 2

More detail model of hybrid power system performance with focus on operations between components.

Hybrid2 is still around but is primarily supported by the University of Massachusetts – DOE/NREL stopped funding them about 5 years ago, but still keep in the loop.

Hybrid 2 is available for download at:

http://www.ceere.org/rerl/rerl_hybridpower.html

Hybrid 2

Current plans: none

There is little interest in software development/support of this sort around the wind program and except for work in Alaska and Antarctica, not a lot of corporate support for remote power systems.

Feature notes:

Hybrid2 can account for ambient temperature in modeling PV systems – so if you have temperature data, Hybrid2 will include this in its efficiency and finally power output calculations. It does not include a link to the wind speed (since the wind speed at the wind turbine height is very different than the wind speed on the ground) but at some point it would be possible to add this in.

Hybrid 2

Alaska Energy Authority (Basically the Alaska state energy office) has a strong interest in off grid power systems and the ability to model them more accurately than you get with HOMER.

Currently in the process of negotiating a 3 year, major upgrade of the software with the University of Massachusetts.

This would greatly improve the modularity of the code, improve the interface, change the software from a power base to an electrical base (volt and amp) and add components that are important to the Alaskans – such as flywheels.

UMass has also done stuff like developed an expanded battery life calculation and a hydrogen fuel module that they are thinking of formally adding in the new revision.

Hybrid2

E. Ian Baring-Gould

Senior Mechanical Engineer

National Wind Technology Center

National Renewable Energy Laboratory - MS3811

1617 Cole Blvd. Golden, Colorado 80401-3393 USA

Phone: (+1) 303 384-7021 - Fax: (+1) 303 384-7097

Cell: (+1) 303-999-6661 – note new cell number

Email: ian_baring-gould@nrel.gov

www.nrel.gov